

OZthermTM

Solid State Relays

F-100

SOLID STATE RELAYS

*

FEATURING
FAST SWITCHING FOR
CONTROL OF AC OUTPUT

*

DESIGNED
and
MANUFACTURED
by

Fastron
TECHNOLOGIES PTY. LTD.

Fastron first released their " X " Series of S.C.R. Power Controllers in 1980, progressively developing over 20 different models and selling over 1000 controllers worldwide.

These controllers were primarily designed as custom built, open frame, OEM assemblies sold directly to equipment manufacturers.

The **OZtherm™** range of controllers capitalize on our experience in this field to provide a reliable and robust design housed in a series of standard assemblies and enclosures.

- F100 SERIES** Contactors utilizing CRYDOM solid state relays mounted on a Heat Sink Assembly with fuses and transient suppressors.
- F200 SERIES** Solid State Contactors utilizing S.C.R.'s and control card mounted in standard enclosures.
- F300 SERIES** Phase Angle Controllers utilizing S.C.R.'s and control card mounted in standard enclosure's
- F400 SERIES** Burst Controllers, similar to F300 in construction, featuring fast cycle, zero cross switching.

BENEFITS OF THE **OZtherm™** F100 SOLID STATE RELAY

- High speed, noiseless and bounceless electronic switching offers superior performance over mechanical systems
- No moving parts, no mechanical contacts and microprocessor compatible
- Low EMI and RFI on zero cross types
- Proudly Australian Designed and Manufactured in our Melbourne factory enabling us to provide complete local support for customer applications, engineering and service.

TYPICAL APPLICATIONS

Security systems	Production equipment	Instrument systems
Fire Alarm systems	Contactor replacement	Test systems
Dispensing Machines	Commercial laundries	Office machines
Navigation equipment	Medical equipment	Traffic control
Temperature controls	Lighting displays	Motor control
Amusement park rides	Elevator controls	Vending machines

Please note that electrical isolation is not provided by a Solid State Relay in the "off" state.

MODEL DESIGNATION / ORDER CODE

SINGLE PHASE

F110 - [] - [] - [] -				DESCRIPTION	Fuse Rating	Case Size	Weight KG	Dissipation Watts	I ² t Thyristor Rating
Line Voltage	1			110 volt A.C line input (1 phase)					
	2			240 volt A.C line input (1 phase)					
	4			415 volt A.C line input (1 phase)					
Rated Current at 50 deg. Celcius.	25			25 amperes A.C line current	25AF	fig.4	0.689	29	260
	40			40 amperes A.C line current	45AF	fig.5	1.136	47	1,620
	50			50 amperes A.C line current	55AF	fig.6	2.447	60	1,620
	75			75 amperes A.C line current	80AF	fig.7	2.862	95	4,150
	90			90 amperes A.C line current	95AF	fig.8	2.779	120	4,150
Options.	A			AC Control input (90-280 VAC)	Zero cross				
	D			DC Control input (3-32 VDC)	Zero cross				
	DR			DC Control input (3.5 - 26 VDC)	Random				
	F			Semiconductor fuses	Includes mounting hardware				
	S			R-C Snubber	Instead of standard Varistor				

THREE PHASE

F130 - [] - [] - [] -				DESCRIPTION	Fuse Rating	Case Size	Weight KG	Dissipation Watts	I ² t Thyristor Rating
Line Voltage	1			110 volt A.C line input (3 phase)					
	2			240 volt A.C line input (3 phase)					
	4			415 volt A.C line input (3 phase)					
Rated Current at 50 deg. Celcius.	20			20 amperes A.C line current	25AF	fig.9	2.04	72	450
	25			25 amperes A.C line current	25AF	fig.10	4.125	100	450
	50			50 amperes A.C line current	55AF	fig.11	4.075	180	1,620
	75			75 amperes A.C line current	80AF	fig.11	4.075	285	4,150
	90			90 amperes A.C line current	95AF	fig.12	6.771	360	4,150
Options.	A			AC Control input (90-280 VAC)	Zero cross				
	D			DC Control input (3-32 VDC)	Zero cross				
	DR			DC Control input (3.5 - 26 VDC)	Random				
	F			Semiconductor fuses	Includes mounting hardware				
	S			R-C Snubber	Instead of standard Varistor				

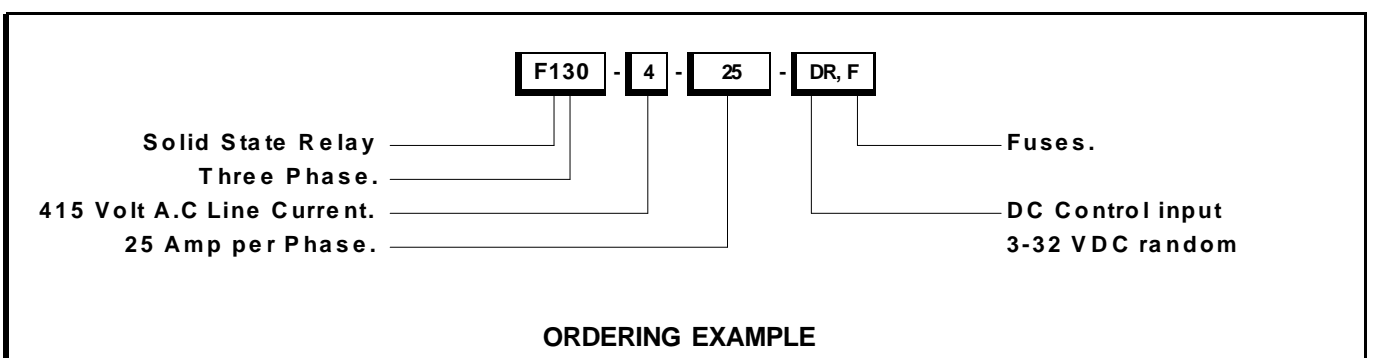

STANDARD SPECIFICATIONS (Table 1)

Control Mode	On / off
Maximum Current	20 - 90 amperes (higher currents available on request)
Power Supply	110/240/415 volts A.C . 50 HZ. +/- 10% (60 HZ. and other voltages available on request)
Transient Protection	MOV (varistor)
Control Input	3.5 - 26 VDC (receiving impedance 1000 ohms nom.) 3 - 32 VDC (receiving impedance 1500 ohms nom.) 90 - 280 VAC (receiving impedance 60K ohms)
Temperture Range	0 - 50 degs. celcius
Ambient Humidity	0 - 85% relative humidity
Power Factor	Unity

DIMENSIONS / MOUNTING DETAILS SINGLE PHASE

Shown mounted vertically in cabinet. Mounting is via vertical bolt head slots in the heatsink.

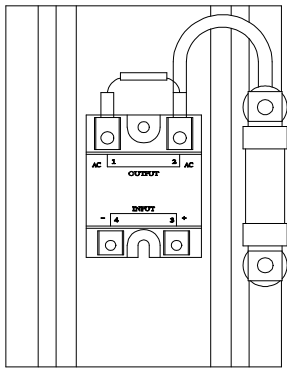

H x W x D = 145 x 106 x 84 mm
Slot = 93.6 mm for M5 bolt

Fig.4

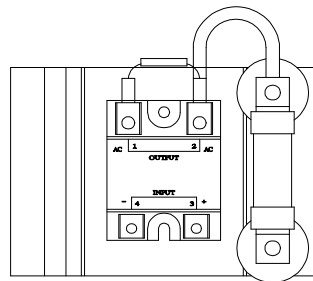

H x W x D = 85 x 120 x 166 mm
Slot = 85 mm for M8 bolt

Fig.5

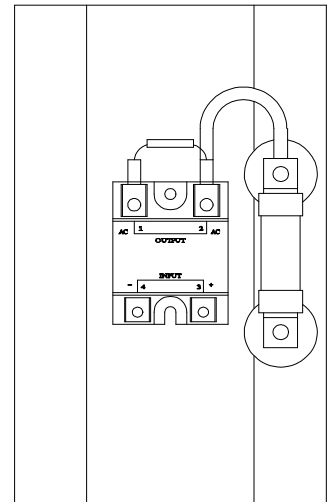

H x W x D = 200 x 120 x 166 mm
Slot = 85 mm for M8 bolt

Fig.6

PLEASE NOTE;- If your application requires the Solid State Contactor to function differently to our standard specifications or you are uncertain about the choice of options please contact the factory.

DIMENSIONS / MOUNTING DETAILS SINGLE AND THREE PHASE

Shown mounted vertically in cabinet. Mounting is via vertical bolt head slots in the heatsink.

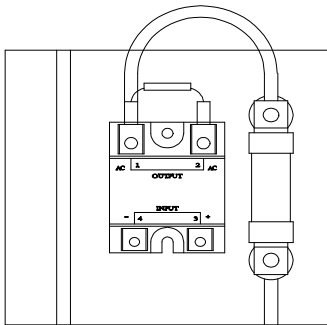

H x W x D = 110 x 125 x 181 mm
Slot = 110 mm for M5 bolt

Fig.7

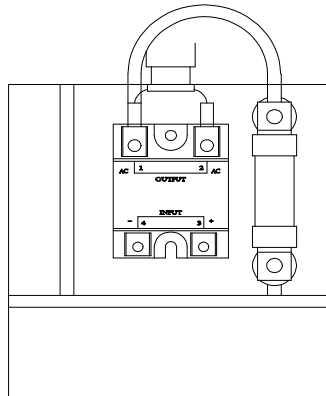

H x W x D = 135 x 125 x 181 mm
Slot = 110 mm for M5 bolt

Fig.8

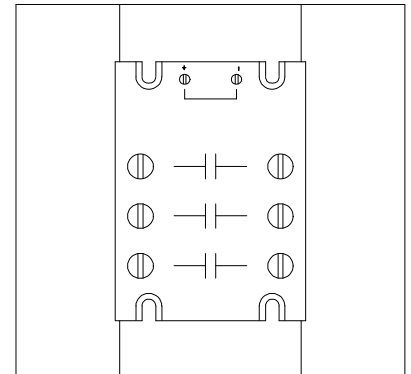

H x W x D = 150 x 150 x 93 mm
Slot = 134 mm for M6 bolt

Fig.9

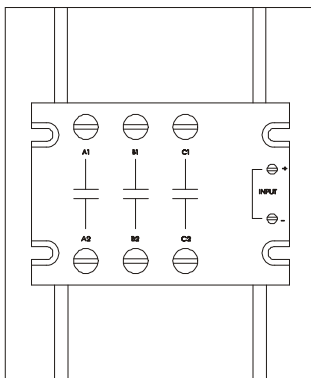

H x W x D = 150 x 125 x 155 mm
Slot = 110 mm for M5 bolt

Fig.10

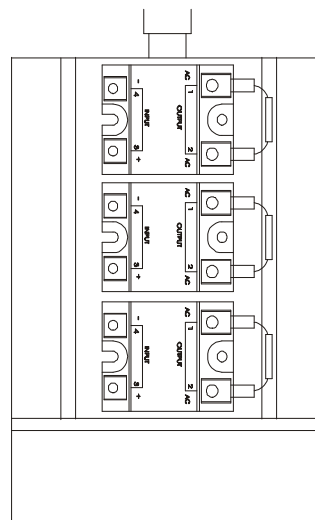

H x W x D = 219 x 125 x 181 mm
Slot = 110 mm for M5 bolt

Fig.11

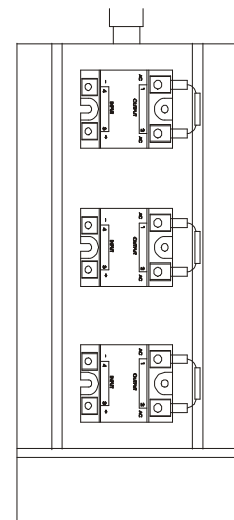

H x W x D = 304 x 125 x 181 mm
Slot = 110 mm for M5 bolt

Fig.12

CIRCUIT CONFIGURATION

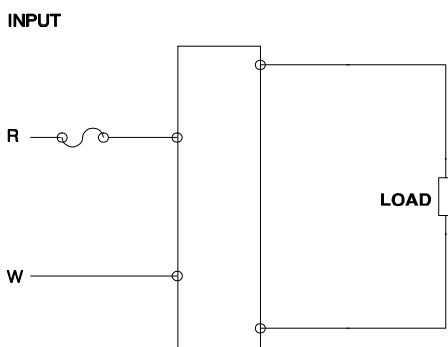

F110 SOLID STATE RELAY

Fig.13

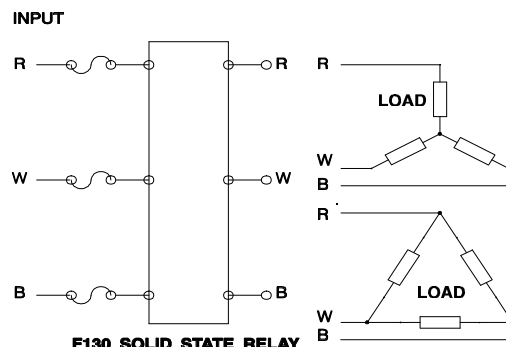

F130 SOLID STATE RELAY

NEUTRAL MAY BE CONNECTED TO STAR POINT IF REQUIRED

Fig.14



OZTHERM POWER PRODUCTS

Thyristor based power controllers offer numerous benefits.

They are a reliable replacement for electromechanical contactors , being virtually maintenance free.

Thyristor based power controllers are ideal for controlling complex loads , such as heating elements that change resistance over time or temperature , transformer coupled loads , plating rectifiers and fast systems.

PRINCIPLE OF OPERATION

Oztherm power controllers consist of two main parts , the control electronics and the power switching electronics.

Thyristors , also known as SCRs , are used as the power switching devices.

A thyristor functions like a diode that can be “turned on” by a momentary pulse to its gate. When a thyristor has been turned on via its gate and its anode is positive relative to its cathode it will conduct.

The thyristor turns itself off when there is near zero current through it.

To control full wave AC over the positive and negative half cycle two thyristors arranged in inverse parallel are required.

The control electronics provide the firing impulses for the thyristor gates. The control input signal is measured and the timing of the gate firing impulses are varied in response to it.

Three types of firing mode are available on Oztherm power controllers.

Phase angle control works by varying the conduction angle of the AC sine wave.

Burst control modulates power by turning the thyristors on and off for AC cycles. The control electronics turn the thyristors on at a position determined by the control signal and off at zero current. The output is the ratio of OFF time to ON time.

On/ Off control is similar to burst control and is like an “electronic relay” in operation.

F100 and F200 series power controllers use the on/ off firing mode

F300 series power controllers use the phase angle firing mode.

F400 series power controllers use the burst firing mode.

SELECTING THE CORRECT CONTROLLER FOR HEATING ELEMENT TYPES

Heating elements can be broadly divided into three categories:-

CLASS A

These elements have negligible resistance variation with either temperature or time. Examples include: Nickel/Chromium or similar alloys.

CLASS B

These elements have a low cold temperature resistance that increases greatly at operating temperature. Examples include: Molybdenum Disilicide, Platinum and Molybdenum Tungsten

Class B elements usually require current limit on start up, as their low cold resistance results in high currents at the operating supply voltage. These elements may also require a stepdown transformer to match the supply voltage to the rated element voltage.

Because current limit is required, and the element voltage ratings are less than line voltage, phase angle control (F300 series controllers) is the recommended firing mode.

CLASS C

The resistance of these elements increases greatly with time in use (typically 2 to 4 times) and with temperature. Silicon carbide is a common example. The power controller must be sized so that it can deliver the higher currents required to maintain the desired power when the elements are new. If the elements are sized correctly the use of a stepdown transformer may be avoided.

The power limit (PW) option is recommended for this class of element as it compensates for element ageing and limits the maximum load power. Phase angle (F300 series controllers) is the recommended firing mode.

CONTROLLER SELECTION AND ELEMENT TYPE

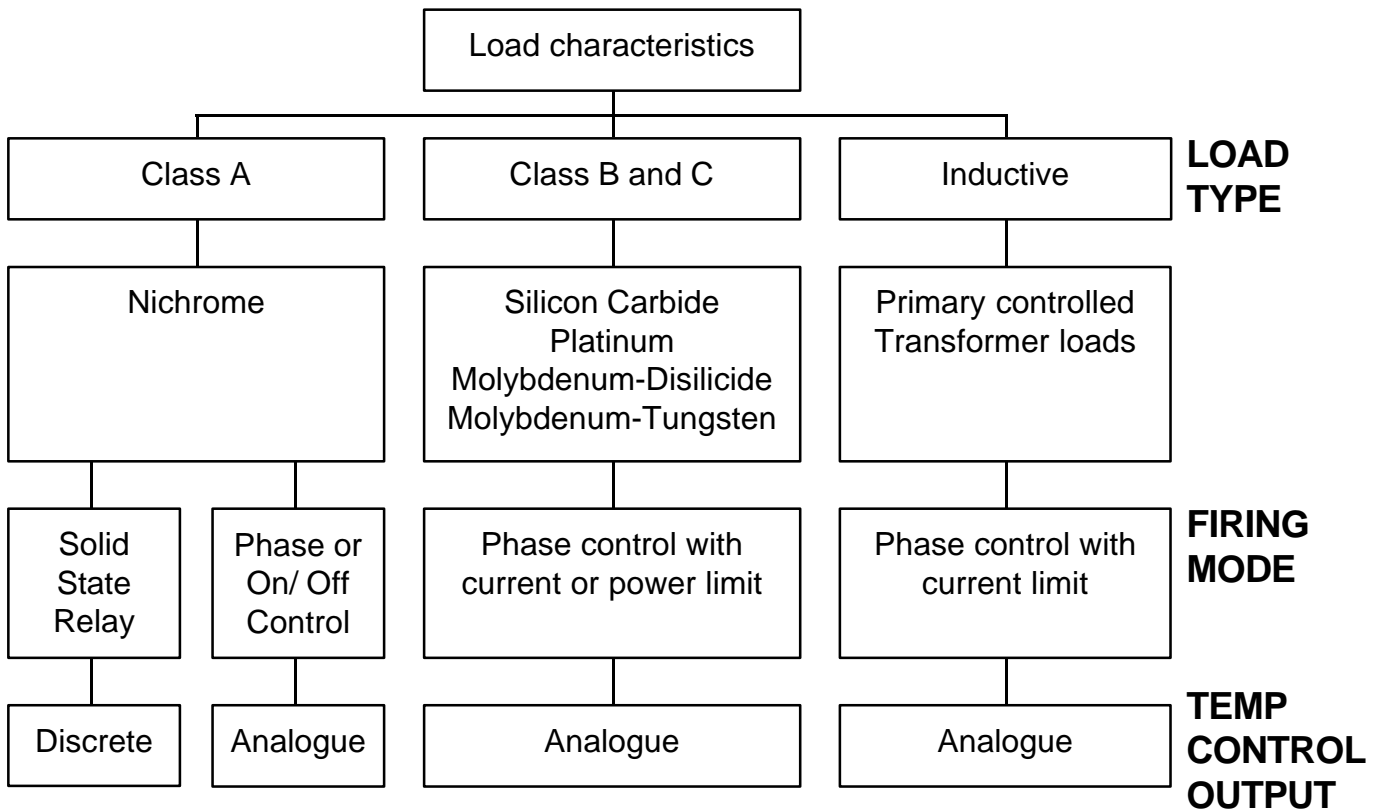

VOLTAGE WAVEFORMS FOR ON/ OFF AND PHASE ANGLE CONTROL

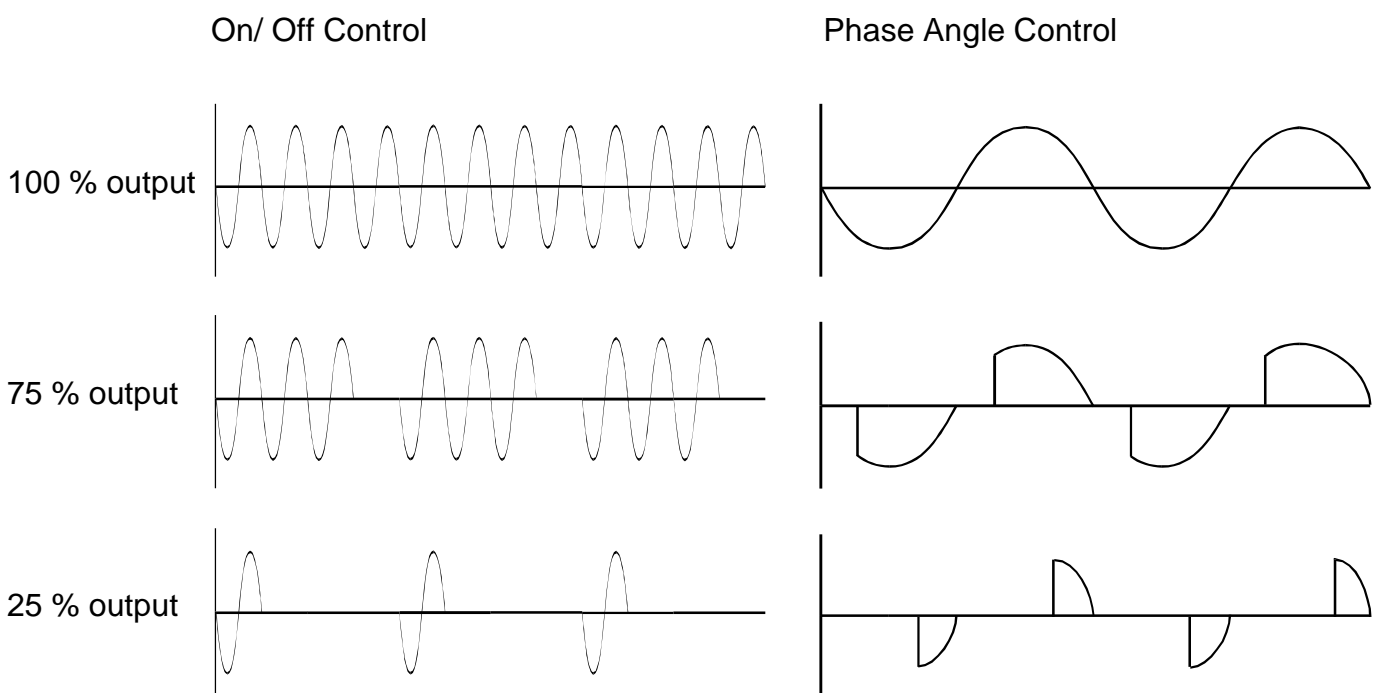



HEAD OFFICE
25 Kingsley Close
Rowville 3178
Victoria Australia

Tel: 61- 3 9763 5155 Fax: 61-3 9763 5166
Email;- fastron@ozemail.com.au